

TRILOS Three Roll Mill Specifications and Dimensions

Models

- Laboratory Benchtop Model TR50M
- Pilot-Scale Production Model TR80A
- Industrial Production Model TR120A

Standard Features

Shell:

- TR50M/TR80A: Aerospace grade carbon fiber with anticorrosive paint and TPU type paint protection film
- TR120A: Aluminium alloy with anticorrosive paint and TPU type paint protection film

Roll: Precision ground ceramic rolls that are cored to allow water cooling or heating

Roll Materials: Stainless steel, ZrO₂ (Zirconia), Al₂O₃ (Alumina), SiC (Silicon Carbide) are available.

Endplates: adjustable POM type endplates

Apron:

- TR50M: Surface hardening POM type apron
- TR80A/TR120A: Surface hardening aerospace grade aluminum

Motor:

- TR50M: 120W stepper motor with nylon gears
- TR80A/TR120A: 1.5kW/3kW stepper motor with nylon and 40Cr gears

Touchscreen: TR80A and TR120A are equipped with 7 inch digital touchscreen with PLC system.

TRILOS IoT Platform: It is optional and available for TR80A and TR120A.

Fixation:

- TR50M/TR80A: metal feet
- TR120A: Adjustable leveling casters

Accessories

Available accessories: dust cover, charging hopper, safety light curtain, barred charging hopper, circulating water bath. Other custom accessories can be supplied if required.

Specifications

Model	TR50M		TR80A		TR120A	
Capacity	0.02~5 L/hr	0.005~1.3 gal/hr	0.02~20 L/hr	0.005~5.3 gal/hr	0.5~60 L/hr	0.13~15.9 gal/hr
Roll Diameter	50 mm	2 inch	80 mm	3.2 in	120 mm	4.7 in
Roll Length	150 mm	5.9 in	200 mm	7.9 in	450 mm	17.7 in
Power	0.12 kW	0.16 HP	1.5 kW	2 HP	3.5 kW	4.7 HP
Dimensions	390×215×370 mm	15.4×8.5×14.6 in	750×340×490 mm	29.5×13.4×19.3 in	1150×660×1280 mm	45.3×26×50.4 in
Weight	20 kg	44 lb	110 kg	243 lb	350 kg	772 lb

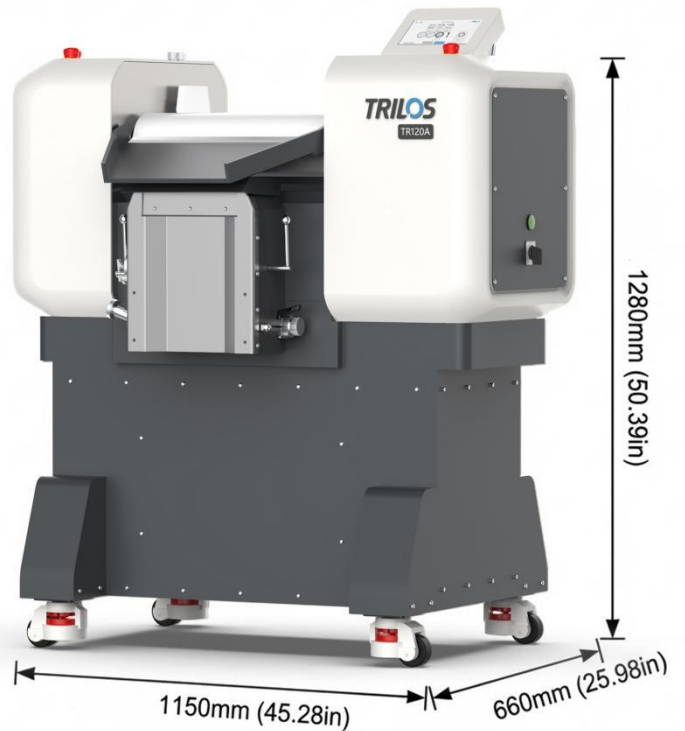
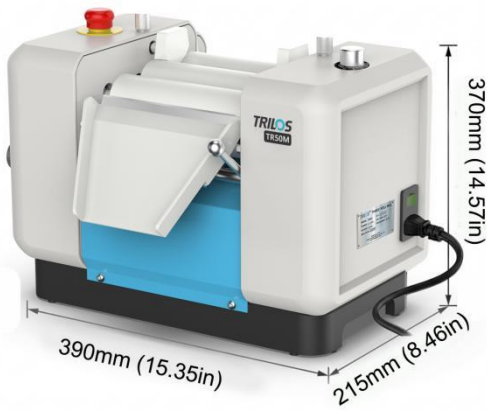

TRILOS (Shanghai) Precision Machinery Co., Ltd.

Address: Tus-Caohejing (Zhongshan) Science Park, Zijing Park, No.85 Mingnan Road, Songjiang District, Shanghai, China

Website: <https://www.trilosgroup.com/en/> | Email: info@trilosgroup.com